

# PD138 Minimux® II Temperature & Process Scanner



**MINIMUX® II**



- 8 Inputs Per Unit, Eliminates Need for 7 Displays
- Unlimited Number of Units Per System
- Free Custom Message Labels
- Thermocouples, RTDs, Process, AC & DC Inputs
- Internally or Manually Controlled Scanning
- Adjustable Dwell Time for Each Channel
- Independent Alarm Input for Each Channel
- First-Out Alarm Indication
- Alarms Indicated by LEDs, Built-in Horn, and Relay
- Built-In 85 dB Horn with Silence Pushbutton
- Stop-On-Alarmed Channel (field select)
- Non-Interruptible 4-20 mA Inputs
- Sunlight Readable Indication
- NEMA 4X / IP65 Front
- Shallow Depth 1/8 DIN Enclosure
- -40 to 65°C Operating Temperature Range

**PRECISION DIGITAL CORPORATION**  
89 October Hill Road • Holliston MA 01746 USA  
Tel (800) 343-1001 • Fax (508) 655-8990

**PRECISION  
DIGITAL**   
[www.predig.com](http://www.predig.com)

## Disclaimer

The information contained in this document is subject to change without notice. Precision Digital makes no representations or warranties with respect to the contents hereof and specifically disclaims any implied warranties of merchantability or fitness for a particular purpose.

	
<b>CAUTION:</b> Read complete instructions prior to installation and operation of the meter.	<b>WARNING:</b> Risk of electric shock or personal injury.



## Warning

This product is not recommended for life support applications or applications where malfunctioning could result in personal injury or property loss. Anyone using this product for such applications does so at his/her own risk. Precision Digital Corporation shall not be held liable for damages resulting from such improper use.

## Limited Warranty

Precision Digital Corporation warrants this product against defects in material or workmanship for the specified period under "Specifications" from the date of shipment from the factory. Precision Digital's liability under this limited warranty shall not exceed the purchase value, repair, or replacement of the defective unit.

## Registered Trademarks

All trademarks mentioned in this document are the property of their respective owners.

© 2009 Precision Digital Corporation. All rights reserved.

[www.predig.com](http://www.predig.com)

## Table of Contents

<b>INTRODUCTION</b> .....	<b>5</b>
<b>ORDERING INFORMATION</b> .....	<b>6</b>
<b>SPECIFICATIONS</b> .....	<b>7</b>
<b>SETUP AND PROGRAMMING OVERVIEW</b> .....	<b>8</b>
<b>SAFETY INFORMATION</b> .....	<b>9</b>
<b>INSTALLATION</b> .....	<b>9</b>
Unpacking.....	9
Panel Mounting.....	10
<b>CONNECTIONS OVERVIEW</b> .....	<b>11</b>
<b>SIGNAL CONNECTIONS</b> .....	<b>11</b>
Three-Wire RTD Inputs.....	12
Thermocouple Inputs.....	12
4-20 mA Inputs.....	13
Voltage Inputs.....	14
<b>MULTIPLE PD138 CONNECTIONS</b> .....	<b>15</b>
<b>ALARM-IN CONNECTIONS</b> .....	<b>17</b>
<b>ALARM RELAY CONNECTIONS</b> .....	<b>18</b>
Connections.....	18
<b>EXTERNAL SIL, ACK, &amp; STOP/GO CONNECTIONS</b> .....	<b>19</b>
<b>PROGRAMMING OVERVIEW</b> .....	<b>19</b>
Front Panel Pushbuttons and Status LED Indicators.....	20
Programming Dwell Time .....	21
Programming Dwell Time for Multiple PD138 System .....	22
Returning to Four-Second Default Dwell Time .....	22
<b>PROGRAMMING ALARM SEQUENCES</b> .....	<b>22</b>
Stop or Continuous Scanning On Alarm.....	22
Selecting Alarm Sequence .....	23
Relay Fail-Safe .....	23
<b>OPERATION</b> .....	<b>24</b>
Scan, Stop Scan & Quick-Scroll .....	24
Stop Scan .....	24
Quick-Scroll .....	24
Multiple Units .....	25
Built-In Horn.....	25
Alarm Relay .....	25
SILENCE, STOP/GO & ACK Buttons .....	25
External SILENCE, STOP/GO & ACK Terminals.....	25
Alarms .....	26
First-Out Alarms (F2A).....	26

Alarm Indication .....	27
<b>ALARM SEQUENCE EXAMPLES .....</b>	<b>28</b>
Sequence A .....	28
If Momentary Alarm.....	29
If Maintained Alarm .....	29
Sequence F2A .....	30
Acknowledge .....	31
Stop-On-Alarm.....	32
<b>MESSAGE LABELS .....</b>	<b>33</b>
<b>MOUNTING DIMENSIONS .....</b>	<b>34</b>

## **Table of Contents**

<b>Figure 1. Panel Cutout and Mounting .....</b>	<b>10</b>
<b>Figure 2. Connector Labeling for PD138 .....</b>	<b>11</b>
<b>Figure 3. Case Dimensions – Side View .....</b>	<b>34</b>
<b>Figure 4. Case Dimensions – Top View .....</b>	<b>34</b>

## **INTRODUCTION**

The Minimax<sup>®</sup> II is a microprocessor-based eight channel analog input scanner/multiplexer and annunciator that provides low-cost automatic switching for multi-point display and alarm systems. Each Minimax<sup>®</sup> II can automatically switch up to eight inputs to another device such as a digital panel meter, controller, or PLC. Multiple units can be connected together to scan an unlimited number of points. Front panel push-buttons allow for easy programming of independent adjustable dwell times as well as rapid channel skipping. The built-in annunciator logic can detect and indicate which input signals are in alarm condition. The built-in horn, alarm relay, and front panel LEDs are sure to catch the operators attention. Signal switching is done with reed relays making the Minimax<sup>®</sup> II ideal for switching thermocouples, RTDs, control loops, and AC & DC signals.

## ORDERING INFORMATION

24 VDC Model	115 VAC Model	230 VAC Model	Description
PD138-2	PD138-3	PD138-4	8 Channel Temp & Process Scanner
PD138-2-CL	PD138-3-CL	PD138-4-CL	8 Channel Temp & Process Scanner with current loop resistor
Notes:			
1. Message labels for the PD138 may be specified at time of order or later. See page 33 for details.			
2. There is no special cable required to connect multiple PD138s together.			

## Enclosures

Model	# of Units	Description	Mounting
PDA2501-V	1	Plastic NEMA 4X Enclosure	Through Door
PDA2502-V	2	Plastic NEMA 4X Enclosure	Through Door
PDA2503-V	3	Plastic NEMA 4X Enclosure	Through Door
PDA2504-V	4	Plastic NEMA 4X Enclosure	Through Door
PDA2505-V	5	Plastic NEMA 4X Enclosure	Through Door
PDA2506-V	6	Plastic NEMA 4X Enclosure	Through Door
PDA2522	2	Plastic NEMA 4X Enclosure; 1(V) 1(H)	Through Door
PDA2601-V	1	Stainless Steel NEMA 4X Enclosure	Through Door
PDA2602-V	2	Stainless Steel NEMA 4X Enclosure	Through Door
PDA2603-V	3	Stainless Steel NEMA 4X Enclosure	Through Door
PDA2604-V	4	Stainless Steel NEMA 4X Enclosure	Through Door
PDA2605-V	5	Stainless Steel NEMA 4X Enclosure	Through Door
PDA2606-V	6	Stainless Steel NEMA 4X Enclosure	Through Door
PDA2622	2	SS NEMA 4X Enclosure; 1(V) 1(H)	Through Door
PDA2701-V	1	Steel NEMA 4 Enclosure	Through Door
PDA2702-V	2	Steel NEMA 4 Enclosure	Through Door
PDA2703-V	3	Steel NEMA 4 Enclosure	Through Door
PDA2704-V	4	Steel NEMA 4 Enclosure	Through Door
PDA2705-V	5	Steel NEMA 4 Enclosure	Through Door
PDA2706-V	6	Steel NEMA 4 Enclosure	Through Door
PDA2722	2	Steel NEMA 4 Enclosure; 1(V) 1(H)	Through Door
PDA2801	1	Plastic NEMA 4X Enclosure	Through Cover

## Systems

Model	Description	Kit Components	
PDS178	Temperature Scanning & Alarming System	PD765-6R2-00 PD138-3 PDA2821	Process & Temperature Meter Minimax II Plastic NEMA 4X Enclosure

## SPECIFICATIONS

<b>NUMBER OF CHANNELS PER MINIMUX</b>	8 double-pole channels per unit
<b>NUMBER OF CHANNELS PER SYSTEM</b>	Unlimited
<b>SIGNALS SWITCHING</b>	DPST reed relays
<b>CONTACT RESISTANCE</b>	0.2 $\Omega$ maximum
<b>MAXIMUM INPUT VOTAGE</b>	200 V (switched or common mode)
<b>MAXIMUM CURRENT SWITCHED</b>	0.5 A
<b>MAXIMUM POWER SWITCHED</b>	10 W
<b>DWELL TIME</b>	Each channel adjustable from 0.6 to 30 seconds
<b>NON-VOLATILE MEMORY</b>	All programming values are stored in non-volatile memory for ten years if power is lost
<b>SCAN METHOD</b>	Internal or manually controlled
<b>CHANNEL INDICATION</b>	Green LED on front panel
<b>DISABLING CHANNELS</b>	Any channel may be disabled
<b>SCAN STOP</b>	The scan may be stopped by pressing and holding the STOP/GO button for more than 0.5 seconds. The scan may be resumed by pressing and releasing the STOP/GO button quickly (less than 0.5 seconds)
<b>ALARM INPUT</b>	Independent alarm input for each channel. Input Impedance; 25 Kohm, typical pull-up to 5 V
<b>ALARM SEQUENCE</b>	Sequence A or Sequence F2A (First-Out)
<b>ALARM OUTPUTS</b>	<p>Alarm condition indicated by:</p> <ol style="list-style-type: none"> <li>1. Front panel red LED for each channel.</li> <li>2. Relay, 1 SPDT (form C); rated 2 A @ 30 VDC or 2 A @ 250 VAC resistive load; 1/4 HP @ 125 / 250 VAC for inductive loads. For fail-safe operation, the relay is energized in the non-alarm state. In the case of a power failure, the relay will go to the alarm state, (NC contact is connected to common).</li> <li>3. Built-in horn, 85 dB.</li> <li>4. Stop-on-alarmed-channel (user select)</li> </ol>





## SAFETY INFORMATION



**CAUTION:** Read complete instructions prior to installation and operation of the instrument.



**WARNING:** Risk of electric shock.



### **WARNING**

Hazardous voltages exist within enclosure. Installation and service should be performed only by trained service personnel.

## INSTALLATION

There is no need to remove the instrument from its case to complete the installation, wiring, and setup.

### **Unpacking**

Remove the instrument from box. Inspect the packaging and contents for damage. Report damages, if any, to the carrier. If any part is missing or the unit malfunctions, please contact your supplier or the factory for assistance.

## Panel Mounting

- Prepare a standard 1/8 DIN vertical panel cutout – 1.772" x 3.622" (45 mm x 92 mm). Refer to Figure 1 for more details.
- Clearance: allow at least 4" (102 mm) behind the panel for wiring.
- Panel thickness: 0.04" - 0.25" (1.0 mm - 6.4 mm).  
Recommended minimum panel thickness to maintain Type 4X rating: 0.06" (1.5 mm) steel panel, 0.16" (4.1 mm) plastic panel.
- Remove the two mounting brackets provided with the meter (back-off the two screws so that there is ¼" (6.4 mm) or less through the bracket. Slide the bracket toward the front of the case and remove).
- Insert the unit into the panel cutout.
- Install mounting brackets and tighten the screws against the panel. To achieve a proper seal, tighten the mounting bracket screws evenly until the front is snug to the panel along its short side. **DO NOT OVER TIGHTEN**, as the rear of the panel may be damaged.

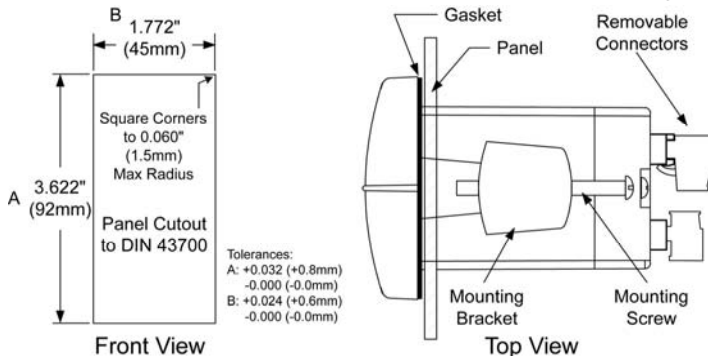

Figure 1. Panel Cutout and Mounting

Note: The PD138 can be horizontally mounted. Free custom message labels can be ordered to align with horizontal mounting, see page 33 or [www.predig.com](http://www.predig.com) for details.



## CONNECTIONS OVERVIEW

All connections are made to removable screw terminal connections which are supplied with each PD138.

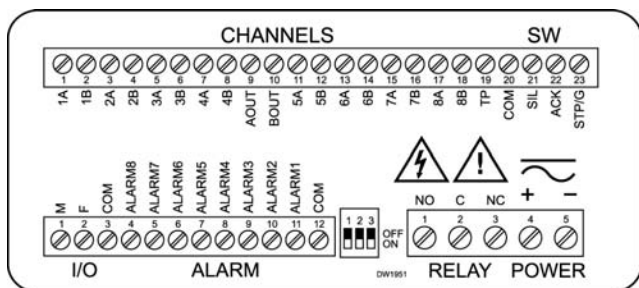

Figure 2. Connector Labeling for PD138

## SIGNAL CONNECTIONS

Signal input and output connections for the Minimux® II are made to a 23 position removable screw terminal connector supplied with each unit. The following table gives the input and output terminal assignments:

CHANNEL	SCREW TERMINAL		RTD COMMON
	+ LINE	- LINE	
3-wire RTD tie point			TP
Input 1	1A	1B	
Input 2	2A	2B	
Input 3	3A	3B	
Input 4	4A	4B	
Input 5	5A	5B	
Input 6	6A	6B	
Input 7	7A	7B	
Input 8	8A	8B	
Output	Output A	Output B	

## Three-Wire RTD Inputs

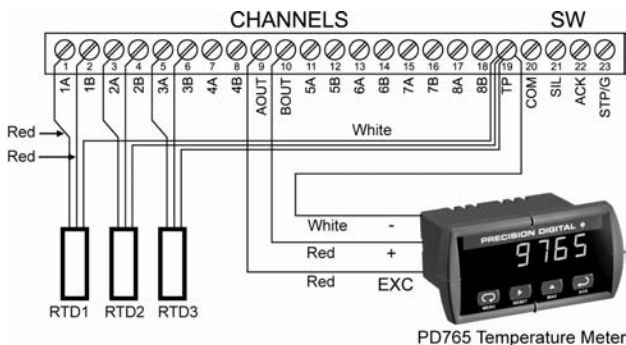

### Note:

Three-wire inputs such as thermistors and RTDs can be handled by switching the two common wires and connecting the third wire of each sensor to the TP terminal and to the temperature meter.

- Connect like color leads to terminals 1A & 1B, 2A & 2B, 3A & 3B, etc.
- Connect odd color leads to terminal TP.
- Connect outputs A, B and TP to the temperature meter.

## Thermocouple Inputs

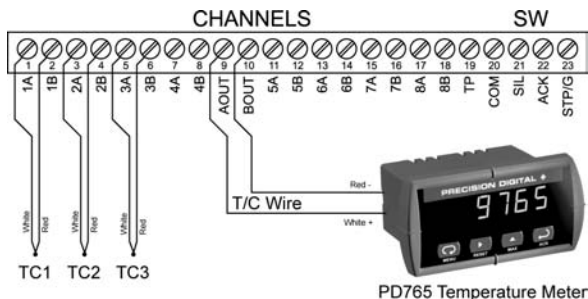

### Note:

Thermocouple wire must be used between the Minimax<sup>®</sup> II and the meter.

## 4-20 mA Inputs

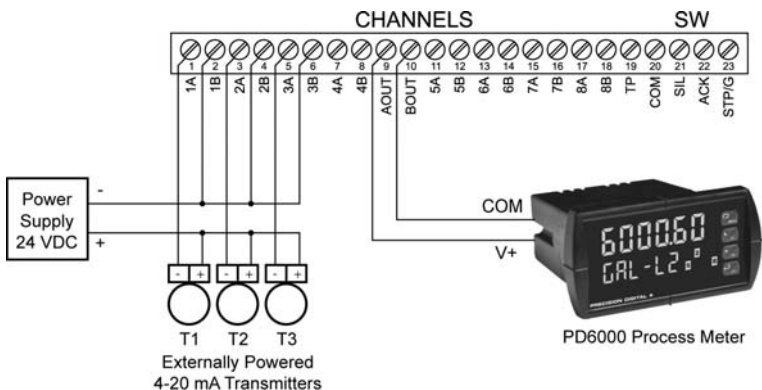

A special version of the Minimax<sup>®</sup> II is used to switch 4-20 mA signals. PD138-X-CL versions have a built-in resistor network that eliminates loop interruptions. The process meter must be setup for 1-5 V input and the complete system should be calibrated together.

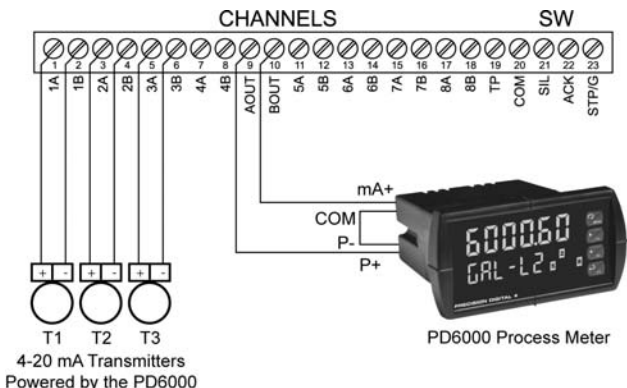

The PD6000's internal transmitter power supply may be used to power the transmitters. However, only the transmitter that is currently selected will be powered and all others will not be powered. Care should be taken to provide the transmitter with sufficient time to stabilize to provide an accurate output.

## Voltage Inputs

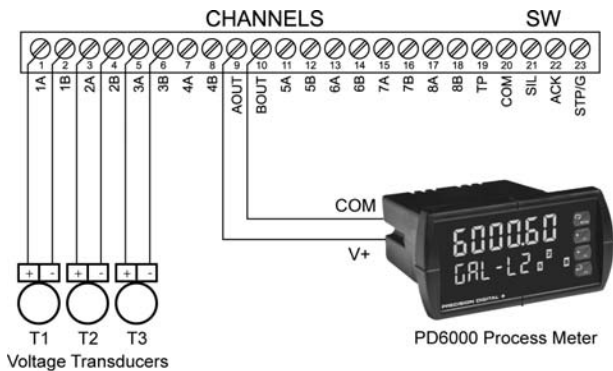

## MULTIPLE PD138 CONNECTIONS

Multiple Minimax® II can be connected together to increase multiplexing capacity for an unlimited number of points. When connecting several units together, one unit of the group is designated the master unit and all other units function as follower units. Multiple unit configuration is simply done by connecting the units together as shown below. The system will self-determine if there are two or more Minimax® II connected together.

No special cable is needed to connect multiple PD138s together.

There are three connections that must be made to connect multiple PD138s into a system:

### 1. Master/Follower Connections

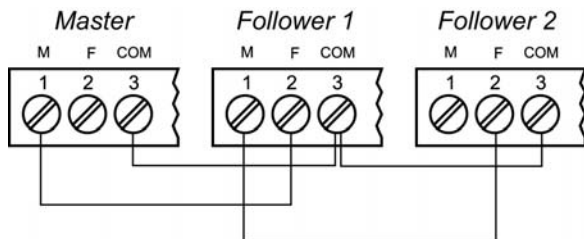

### 2. Multiplexer Output Signal Connections

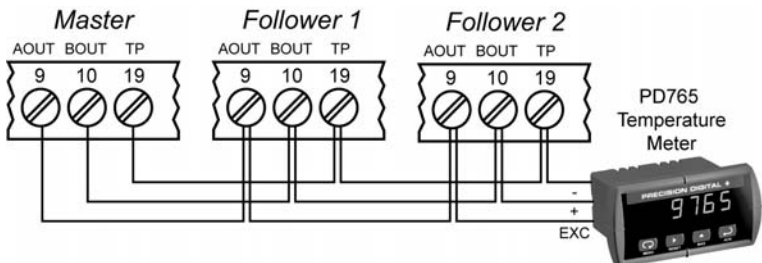

The inputs to each unit are connected as for single units. The outputs of all Minimax® II (terminals output A, output B, and TP) are connected in parallel and then connected to the display meter.

Notes:

1. Use thermocouple wire when interconnecting a thermocouple system.
2. Terminals TP are only used in a three-wire RTD application.

### 3. Silence, Acknowledge, & Stop/Go Connections

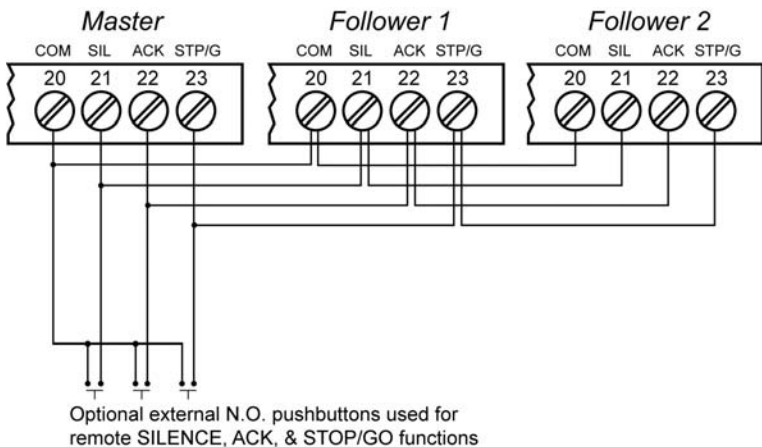

Connecting the ACK & STOP/GO terminals of all units in a multiple-unit system allows the operator to control and acknowledge alarms from any unit in the system or via external switches. However, each Minimax's<sup>®</sup> II relay will operate independently, so it may be necessary to wire them in parallel to drive a single alarm device. Also, each Minimax's<sup>®</sup> II internal horn operates independently.

#### Other Connections

Connections for Power, Signal Inputs, Alarm-In, and Alarm Relay are all made the same way as for single units.



## ALARM-IN CONNECTIONS

Each channel on the PD138 has its own Alarm-In line that provides independent alarm indication capability for each channel. The alarm input lines of the PD138 are normally high (pull-up to 5V). Relay contacts from a Precision Digital meter or a low level logic output from a PLC can be used to drive the PD138 alarm input lines.

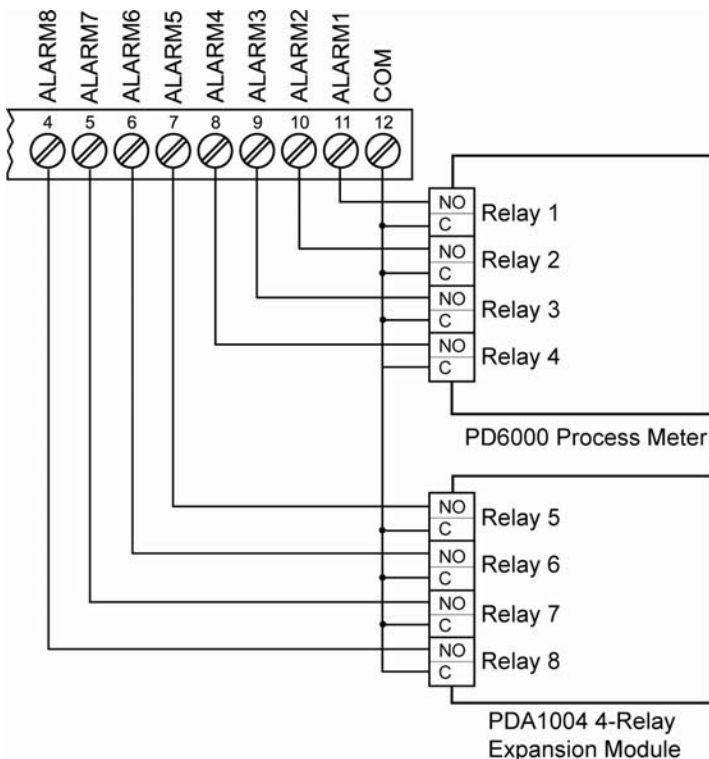

**Note:**

*Under normal condition the NC contact of the PD6000 is opened (failsafe). When the PD6000 goes to alarm the corresponding relay transfers connecting the NC and C contacts together causing an alarm condition to be detected on the PD138.*

## ALARM RELAY CONNECTIONS

One SPDT relay is provided with each unit. This alarm relay is common to all channels and is activated when the PD138 detects an alarm. The relay resets when the alarm is acknowledged.

### Connections

Refer to the diagram below to wire up the alarm relay. When connecting two or more Minimax<sup>®</sup> II together it may be necessary to wire the relays in parallel to drive a single alarm device.

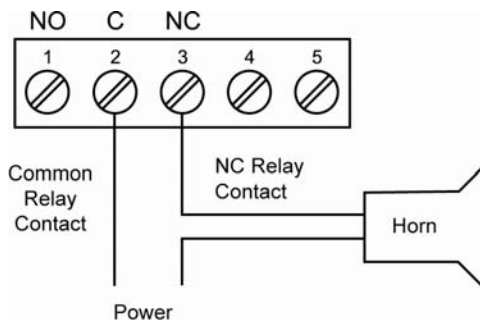

For fail-safe operation, the relay is energized in the non-alarm state. In the case of a power failure, the relay will go to the alarm state, (NC contact is connected to C). See page 23 for details

## EXTERNAL SIL, ACK, & STOP/GO CONNECTIONS

Terminals at the rear of the instrument allow the functions of the SILENCE, ACK, and STOP/GO buttons to be performed externally. For instance, if the PD138 is mounted inside a NEMA 4X enclosure, switches mounted outside the enclosure could be wired to these terminals to provide the user with access to the SILENCE, ACK, and STOP/GO functions.

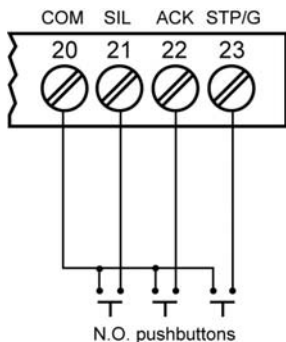

## PROGRAMMING OVERVIEW



The PD138 is programmed for scanning and alarm functions using the front panel buttons and a three-position DIP switch. The DIP switch is used to program the following:

DIP Position	Function
1	Stopping-on-alarm or continuous scan-on-alarm
2	Sequence A or F2A alarm operation
3	Relay fail-safe or normal operation

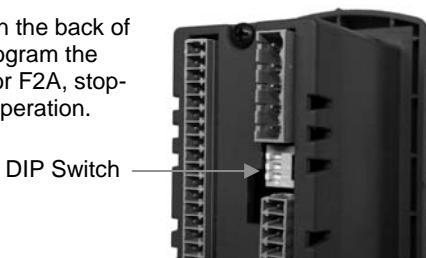
The DIP switch is located on the back of the unit. These switches program the unit for alarm Sequence A or F2A, stop-on-alarm, and for fail-safe operation.



## Front Panel Pushbuttons and Status LED Indicators

Button	Description
	Silence Horn
	Acknowledge Alarm
	Stop/Go
LED	Description
Red	Channel Alarm Status Indicators
Green	Current Channel
Yellow	Current Channel in Alarm Condition
Power	Indicates power is on.

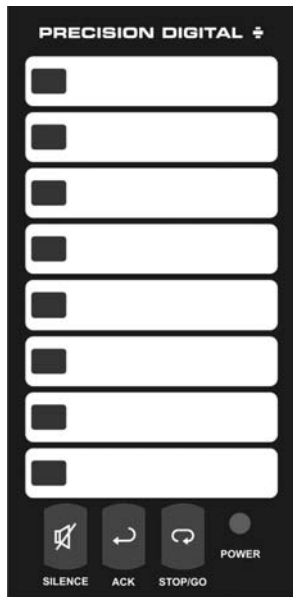

## Programming Dwell Time

The default dwell time for the PD138 is four seconds per channel and it can be adjusted for any time between 0.6 and 30 seconds per channel. A channel can be disabled from the scan sequence by programming that channel's dwell time for less than 0.5 seconds during setup.

To program a dwell time for other than the four second default or to disable a channel altogether:

1. Press and hold SILENCE and STOP/GO for 3 seconds until all LEDs cycle, then release
2. Press and release SILENCE while the LEDs cycle (they will cycle 3 times)
3. Press and release STOP/GO while the LEDs blink as a group (they will blink 3 times)  
Note: While entering the programming mode the POWER LED will blink green but will turn red during the actual programming mode.
4. Unit will beep and channel 1 will illuminate, indicating PD138 is ready to be programmed.
5. Dwell times are programmed with the STOP/GO button;
  - Press and release STOP/GO button within 0.5 seconds to disable a selected channel.
  - Press and release STOP/GO button after the 0.5 seconds beep to program channel for minimum dwell time.
  - Press and hold STOP/GO button for desired length of dwell time up to 30 seconds maximum.
6. After the STOP/GO button is released the unit will beep and go to the next channel.
7. Program the remaining channels in a similar fashion.
8. When the dwell times for all eight channels have been programmed, a red LED will light up next to channels that have been disabled.
9. The ACK button is used to advance to the desired channel.
10. When the dwell times have been programmed as desired press the silence button.

## Programming Dwell Time for Multiple PD138 System

The dwell times for each PD138 in a multiple PD138 system need to be programmed individually.

### Returning to Four-Second Default Dwell Time

To return to the default dwell time of four seconds per channel:

1. Turn the power off
2. Apply power while holding the STOP/GO button.
3. Release the STOP/GO button two seconds after power has been applied.

All dwell time programming is stored in non-volatile memory for 10 years if power is lost.

## PROGRAMMING ALARM SEQUENCES

The DIP switch described on page 19 is used to program the following alarm functions:

DIP Switch	Function
Position 1	Stop-on-alarm or continuous scan-on-alarm
Position 2	Sequence A or F2A alarm operation
Position 3	Relay Failsafe

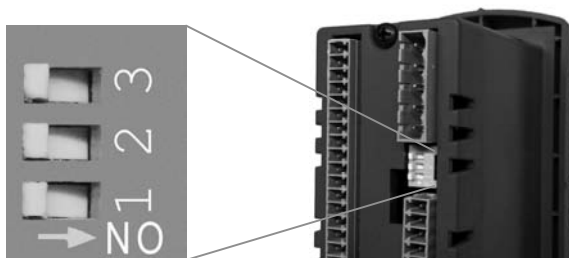

## Stop or Continuous Scanning On Alarm

The PD138 can be programmed to either stop or continue scanning when it encounters a channel in alarm. See page 22 for further details on this function

DIP Switch 1 Position	Function
OFF	Continuous scan ( <i>Factory Default Setting</i> )
ON	Stop-on-alarm

## Selecting Alarm Sequence

The PD138 can be programmed to respond to alarm conditions either via Sequence A or Sequence F2A. Refer to page 26 for a description of these sequences.

DIP Switch 2 Position	Alarm Sequence
OFF	A ( <i>Factory Default Setting</i> )
ON	F2A

## Relay Fail-Safe

In fail-safe operation, a relay coil is energized in non-alarm condition. In case of power failure, relays will go to alarm state.

DIP Switch 3 Position	Relay Action
OFF	Non-Fail-Safe ( <i>Factory Default Setting</i> )
ON	Fail-Safe

*Note: The power must be cycled after making changes to the fail-safe operation.*

## **OPERATION**

In its most basic form, the PD138 is the electrical equivalent to a double-pole, eight position automatic switch. That is, whatever input is brought into the PD138 is dwelled on for a certain amount of time while being switched back out to another device. For example, a typical application may involve switching eight type J thermocouples into a single digital panel meter.

The PD138 is made more useful by adding the ability to indicate alarm conditions. The PD138 can be programmed for either of two alarm sequences and it will indicate alarm conditions in three ways:

1. A red LED lights up next to a message label
2. A built-in horn sounds
3. A 2 amp relay transfers.

Once all the connections have been made to the PD138 and it has been programmed for the particular application, it operates pretty much on its own.

The only intervention it might receive from an operator would be to stop the scan on a particular channel or to acknowledge an alarm.

### **Scan, Stop Scan & Quick-Scroll**

The PD138 automatically scans through each active channel, dwells on that channel for the programmed dwell time, while at the same time switching the signal to an external device.

#### **Stop Scan**

The PD138 can be stopped on the current channel by pressing and holding the STOP/GO key for more than 0.5 seconds. The PD138 will beep once to announce that scanning has stopped. To resume scanning, press and release the STOP/GO key quickly (less than 0.5 seconds).

#### **Quick-Scroll**

To quickly scroll through the channels press the STOP/GO button quickly (less than 0.5 seconds). Repeat until desired channel is reached.



## **Multiple Units**

A system made up of multiple PD138s does not require any special setup or programming. In fact, the model number is the same for all units and they operate in the same manner as single units. There are several terminals on each PD138 in the system that have to be connected together, but this does not require a special cable. Instructions for these connections are described in the Multiple PD138 Connections on page 15.

In a multiple unit system, the scan will progress through each channel on the first PD138, move on to the first channel on the second PD138, scan through its active channels and then move on to additional PD138s in the same manner and then finally come back around to the first channel of the first PD138.

### **Built-In Horn**

Each PD138 has an independent built-in horn. In a multiple unit system the built-in horn of the unit where the alarm condition occurred will activate.

### **Alarm Relay**

In a multiple unit system, only the alarm relay of the unit where the alarm occurred will transfer. The user can wire the alarm relays for all units in parallel to drive a single alarm device.

### **SILENCE, STOP/GO & ACK Buttons**

Connecting the SILENCE, STOP/GO and ACK terminals at the rear of all units in a multiple-unit system allows the operator to control and acknowledge alarms from any unit in the system.

### **External SILENCE, STOP/GO & ACK Terminals**

Connecting a N.O. pushbutton switch across all the STOP/GO & COM terminals in a multiple-unit system allows the operator to control the Minimux® II at a remote location. Connecting a N.O. push-button switch across all the ACK & COM terminals in a multiple-input system allows the operator to acknowledge alarms at a remote location. Connecting a N.O. push-button switch across all the SILENCE & COM terminals in a multiple-input system allows the operator to silence the PD138 at a remote location.

## Alarms

Each channel of the Minimax<sup>®</sup> II has an independent 'Alarm-In' terminal that allows an external device to trigger an alarm on the Minimax<sup>®</sup> II. The external device may be the relay contacts on a digital panel meter, such as the PD765-6R2-00, or the digital output from a PLC. When an external device detects an alarm condition, it drives the appropriate Alarm-In line on the Minimax<sup>®</sup> II low. When the PD138 reaches this channel, its LED will turn red and flash, the built-in horn will sound and the alarm relay will transfer.

Alarms are acknowledged by pressing the ACK button or closing a pushbutton wired across terminals at the rear of the instrument. When an alarm is acknowledged, the horn will silence and the relay will change state. The alarmed LED (red) will not return to normal until the alarm condition has been corrected and that channel is scanned again.

The PD138 can be field programmed to react to alarm conditions in one of two ways: Sequence A or Sequence F2A (first-out). Sequence A detects both momentary and maintained alarms. Sequence F2A also detects both momentary and maintained alarms as well as which alarms occurred first on a complete scan cycle.

### First-Out Alarms (F2A)

The main feature of Sequence F2A is its ability to indicate which alarms occurred first. In a system where all inputs are monitored simultaneously, this is a fairly straightforward concept. However, in a scanned system such as one using a PD138, where the inputs are monitored one at a time, it is not really possible to tell which alarm really occurred first. All that is known is which alarm was detected first. **For this reason, the PD138 recognizes first-out alarms as all alarms that occur during the first complete scan. This is from the time the unit detects the first alarm until the scanning goes around and passes through that first alarmed point once again. First-out alarms are indicated by flashing red LEDs. Secondary alarms are indicated by steady red LEDs.**

The PD138 detects an alarm only if the alarm is present (alarm-in line is low) while the channel is being scanned. For dwell times greater than 2 seconds, the 'alarm-in' line is poled after the PD138 has been on that channel for 2 seconds. If the dwell time is less than 2 seconds, the 'alarm-in' line is poled 0.05 seconds before the PD138 moves on to the next channel.

## **Alarm Indication**

The PD138 indicates alarms in 3 ways:

- 1) A normally green LED turns to red and flashes
- 2) An internal horn sounds
- 3) An alarm relay transfers.

The way red LEDs behave during an alarm depends on whether the PD138 was programmed to respond to alarms via Sequence A or Sequence F2A. Both of these sequences handle both momentary and maintained alarms; Sequence F2A also indicates which group of alarms occurred first.

## ALARM SEQUENCE EXAMPLES

### Sequence A

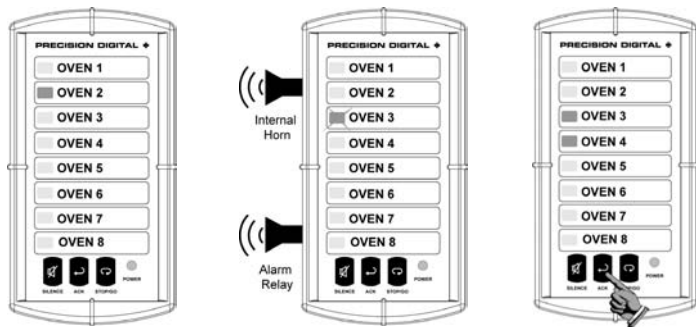

The PD138 is scanning all the selected inputs and is currently at channel 2, as indicated by a green LED.

After the Minimax<sup>®</sup> II has dwelled on channel 3 for the appropriate settling time, it poles channel 3's alarm-in line and finds it to be in alarm. The LED starts flashing yellow (red and green), the horn sounds and the alarm relay transfers.

The unit continues to scan other points and an operator acknowledges the alarm. The internal horn is silenced, the alarm relay transfers, and the number 3 LED goes to steady red.

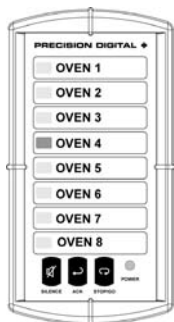

### If Momentary Alarm

When the Minimax<sup>®</sup> II returns to channel 3, the LED will appear yellow (a combination of green and red). Before the Minimax<sup>®</sup> II moves on to the next channel it will check the alarm-in line for channel 3 and find the alarm is gone (momentary) and turn off the red LED. Channel 3's LED will appear green before the Minimax<sup>®</sup> II moves on to channel 4.

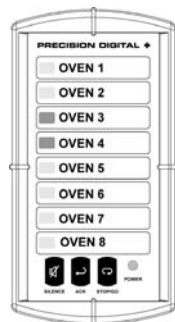

### If Maintained Alarm

When the Minimax<sup>®</sup> II returns to channel 3, the LED will appear yellow (a combination of green and red). Before the Minimax<sup>®</sup> II moves on to the next channel it will check the alarm-in line for channel 3 and find the alarm is still there (maintained) and it will not turn the red LED off.

## Sequence F2A

The main feature of Sequence F2A is its ability to indicate which alarms occurred first (on a scan cycle, see page 26).

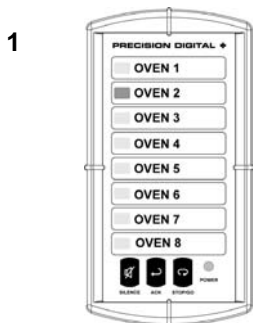

The PD138 is scanning all the selected inputs and is currently at channel 2, as indicated by a green LED.

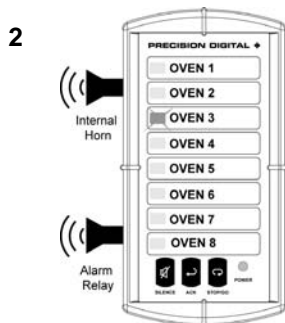

After the Minimax<sup>®</sup> II has dwelled on channel 3 for the appropriate settling time, it poles channel 3's alarm-in line and finds it to be in alarm. The LED starts flashing yellow (red and green), the horn sounds and the alarm relay transfers.

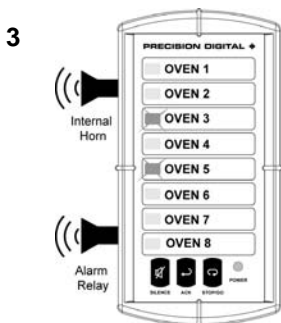

Channel 5 is also found to be in alarm and the LED flashes because it was detected during the same scan cycle that the first alarm was detected.

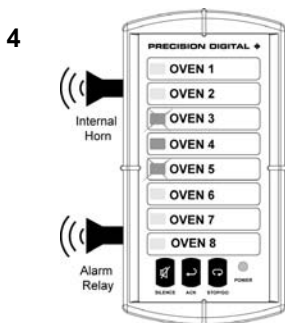

Channel 4 is found to be in alarm and is indicated by a steady LED because it was found after a complete scan of all inputs after the first alarm was detected.

## Acknowledge

5

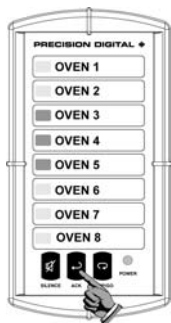

The unit continues to scan and an operator acknowledges the alarm. All LEDs go to steady, the internal horn is silenced, and the alarm relay transfers. When the Minimux<sup>®</sup> II returns to channel 3, the LED will appear yellow. Just before the Minimux<sup>®</sup> II moves on to the next channel it will check the alarm-in line and find the alarm is still there and it will not turn the red LED off.

6

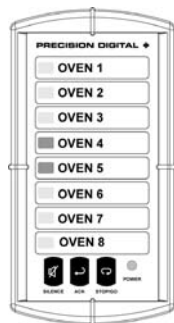

The Minimux<sup>®</sup> II continues to scan and again returns to channel 3, the LED will appear yellow. Just before the Minimux<sup>®</sup> II moves on to the next channel it will check the alarm-in line and find the alarm is gone and turns off the red LED. Channel 3's LED will appear green before the Minimux<sup>®</sup> II moves on to channel 4, which will appear yellow.

## **Stop-On-Alarm**

The PD138 can be programmed to stop scanning when an alarm condition is detected by setting DIP switch 1 to the ON position, as described on page 22.

If the DIP switch is in the ON position, the PD138 will stop when it encounters an alarm and the LED will begin to flash yellow (combination of red and green), the horn will sound and the alarm relay will transfer.

### **There are now two ways to proceed:**

1. Acknowledge the alarm and move on to the next channel by pressing the ACK button. This will cause the horn to silence and the relay to transfer.
2. Remain on the alarmed channel and acknowledge the alarm by pressing and holding the STOP/GO button for more than 0.5 seconds to freeze the scan and then pressing the ACK button to acknowledge the alarm. To resume the scan, press and release the STOP/GO button quickly (less than 0.5 seconds).

If the original alarm has been acknowledged but has not been corrected by the time the scan reaches it again, the scan will stop, but the horn and the relay will not alarm. If the alarm condition has been corrected, the PD138 will continue scanning as normal and the red LED will turn off. If the alarm has not been corrected press the ACK button to continue scanning.



## MESSAGE LABELS

Message labels for the PD138 may be factory-printed at no charge, or field-printed using a laser printer & clear self-adhesive labels. Factory-Printed labels may be ordered at any time by completing the form below. Horizontal mounting labels available, see page 10 for sample.

Make copies of this page for additional message labels.

Please include label with my order.  I have the PD138, please send ASAP.

Vertical Mounting  Horizontal Mounting   
*2 lines, 14 characters per message)* *(2 lines, 11 characters per message)*

Message 1

Message 2

Message 3

Message 4



Message 5

Message 6

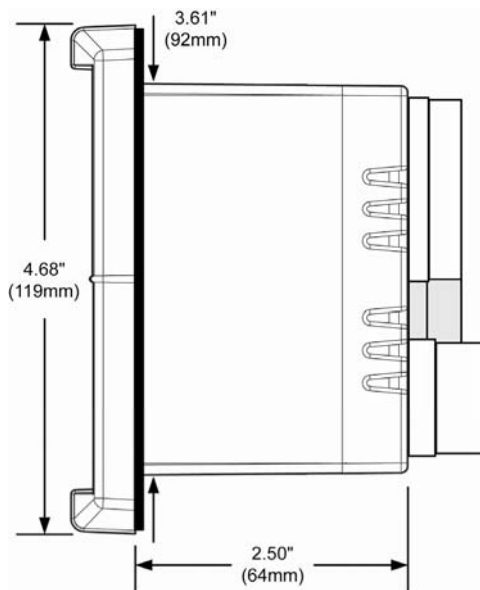

Message 7

Message 8

## MOUNTING DIMENSIONS

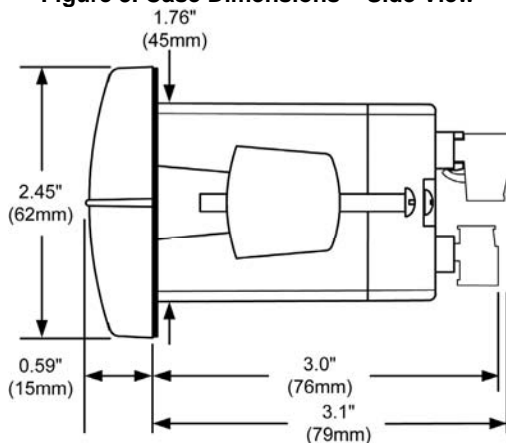

**Figure 3. Case Dimensions – Side View**



**Figure 4. Case Dimensions – Top View**

## NOTES

## How to Contact Precision Digital

- For Technical Support:

Call: (800) 610-5239 or (508) 655-7300

Fax: (508) 655-8990

Email: [support@predig.com](mailto:support@predig.com)

- For Sales Support:

Call: (800) 343-1001 or (508) 655-7300

Fax: (508) 655-8990

Email: [sales@predig.com](mailto:sales@predig.com)

- For the latest version of this manual please visit:

**[www.predig.com](http://www.predig.com)**

